

# Projektarbete sommaren 2015

*Ett internship för utvecklande av en exteriör fullskalemodell av PRT-vagn*



# Vilka är vi?

- Studenter från DPU4
  - Andreas
  - Johan
  - Karin
  - Christine



# Bakgrund

- Kandidatarbete i våras
- Beställaren Beamways AB
- Internship i San Jose, USA
- Spartan Superway Summer Research Program



# Uppgiften

*”Framtagning av en exteriör fullskalemodell av en PRT-vagn för upphängning.”*





SPARTAN  
SUPERWAY

# Involverade personer

- Bengt Gustafsson, Beamways AB
- Johan Ölvander och Micael Derelöv, LiU
- Ron Swenson, Spartan Superway
- Prof. Burford "Buff" Furman, San Jose State University
- Francis "Frank" de Winter, Verkstaden



# Projektomfattning

## **Linköping - 3 veckor**

- Administrativt arbete kring internship
- Planering
- Idégenerering
- Konzeptutveckling

## **San Jose - 4 veckor**

- Byggprocess



# Idégenerering

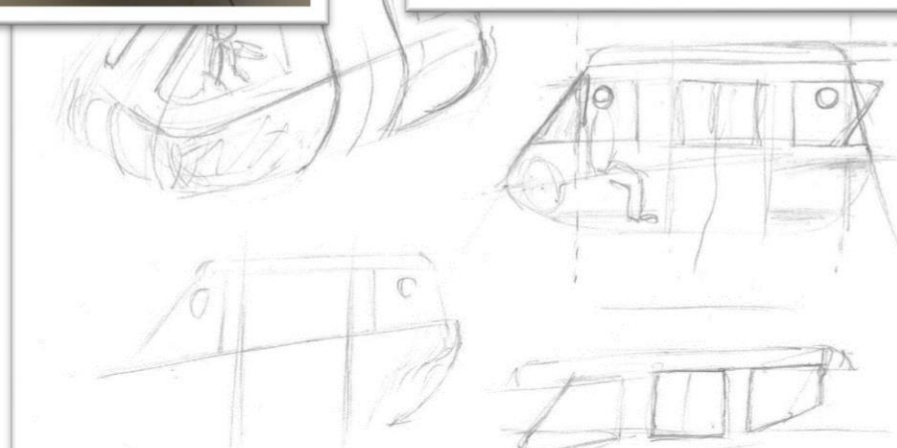
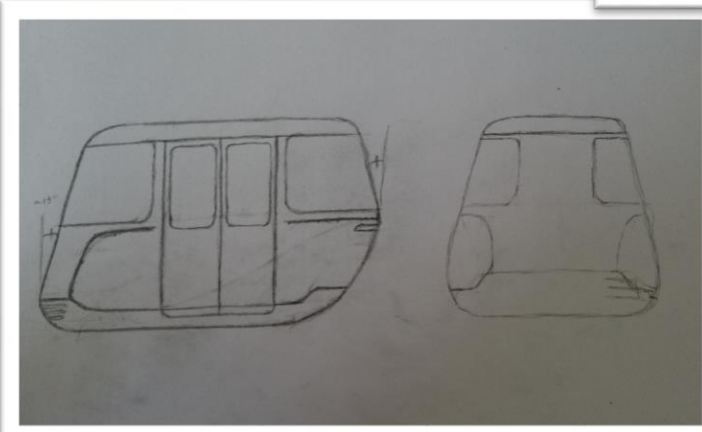
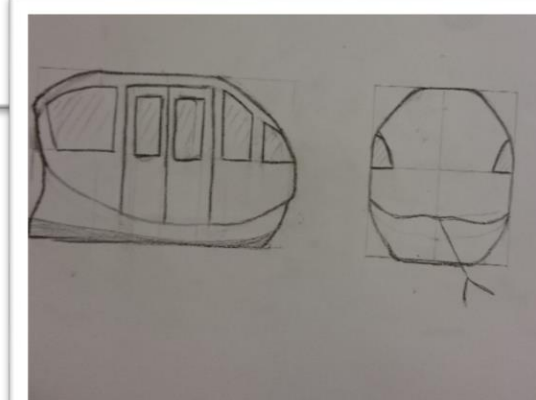
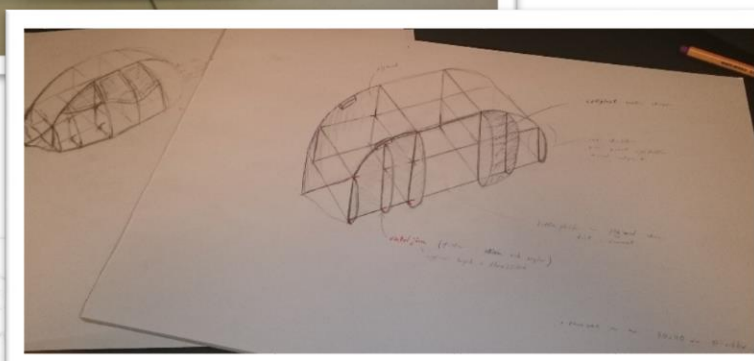
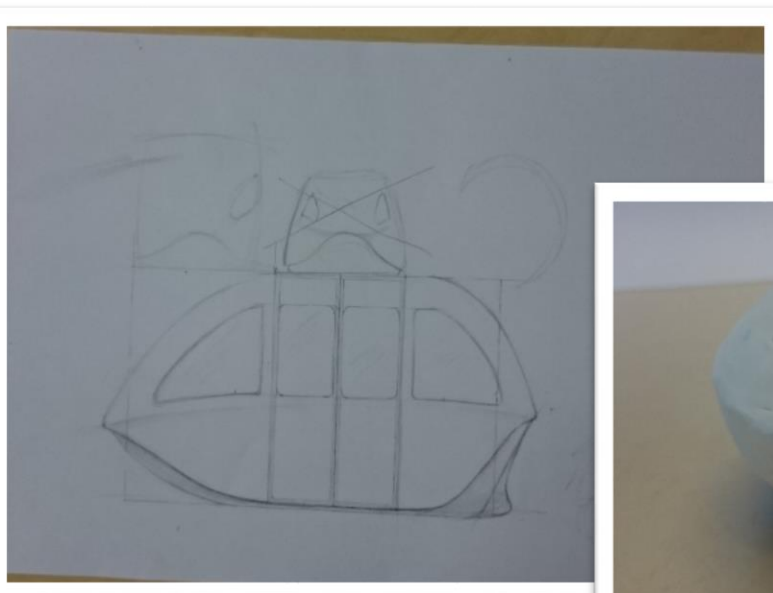
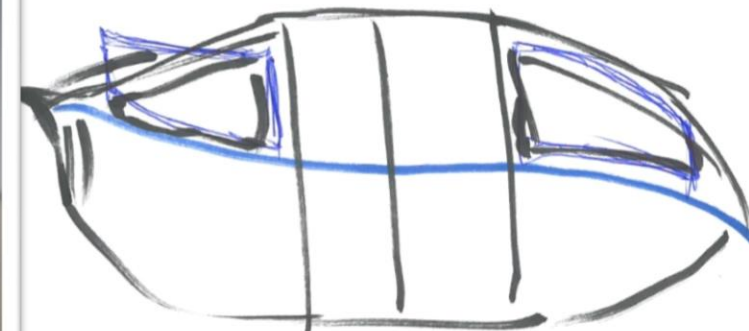



# Konzeptskisser

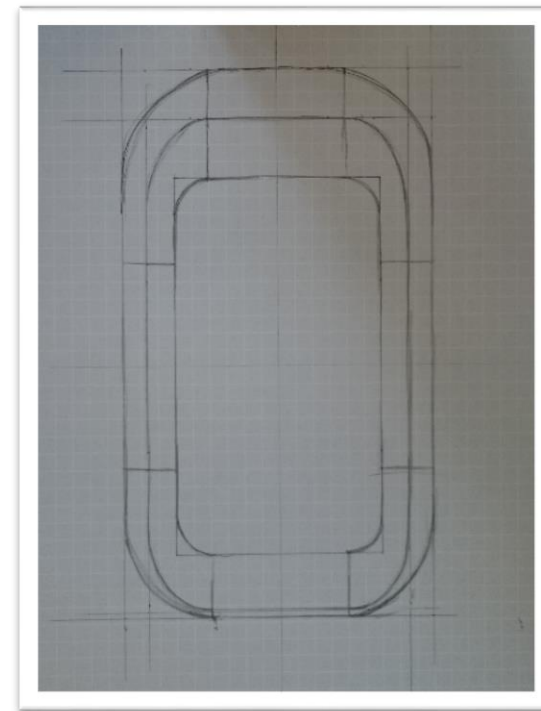
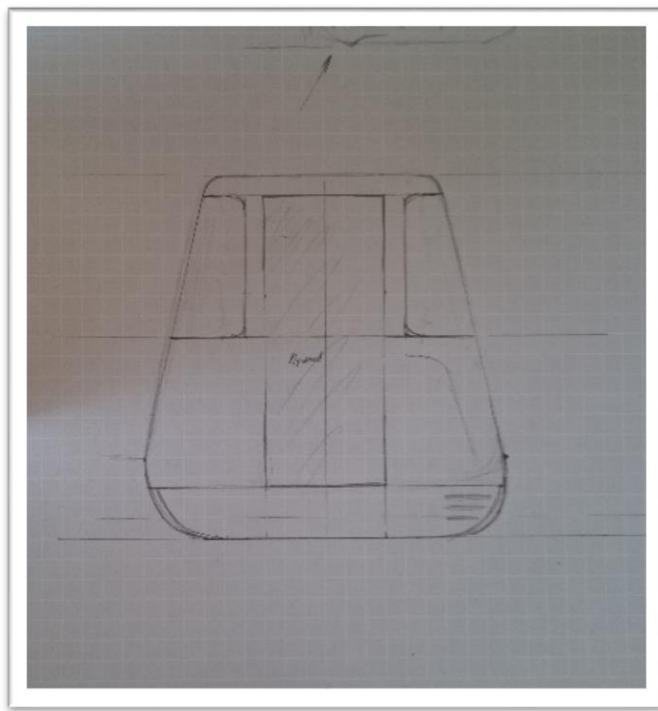
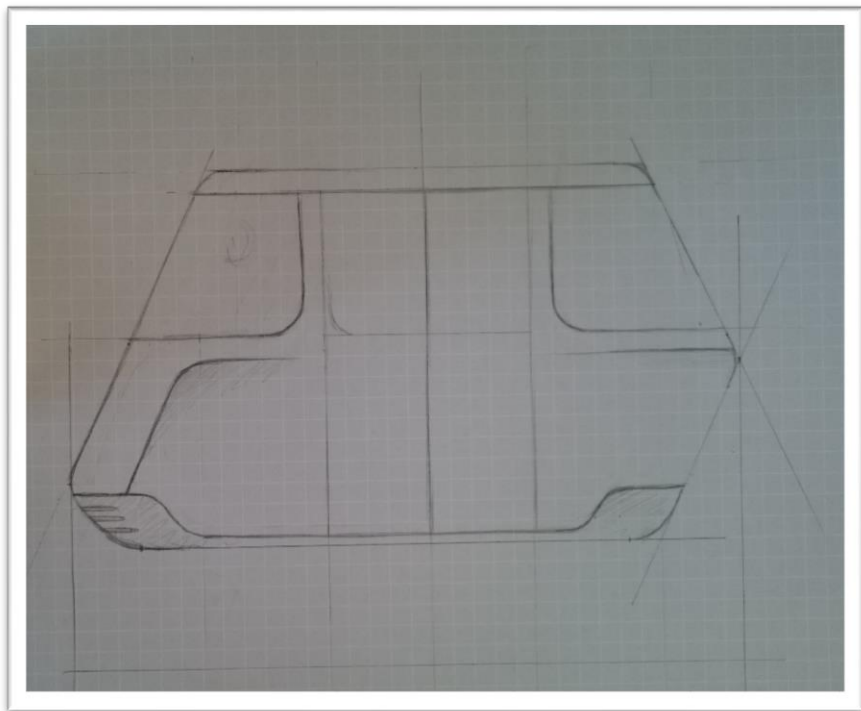

# CAD, konstruktion och form

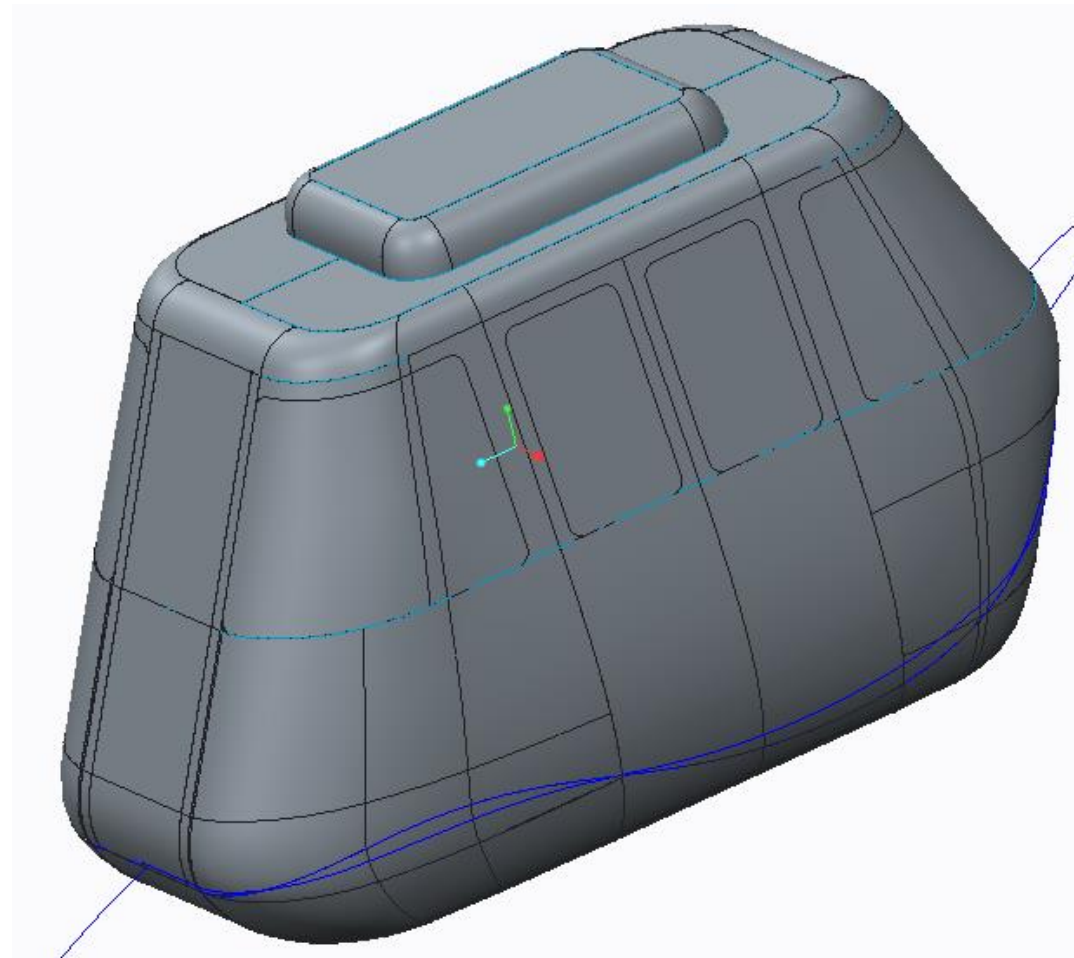
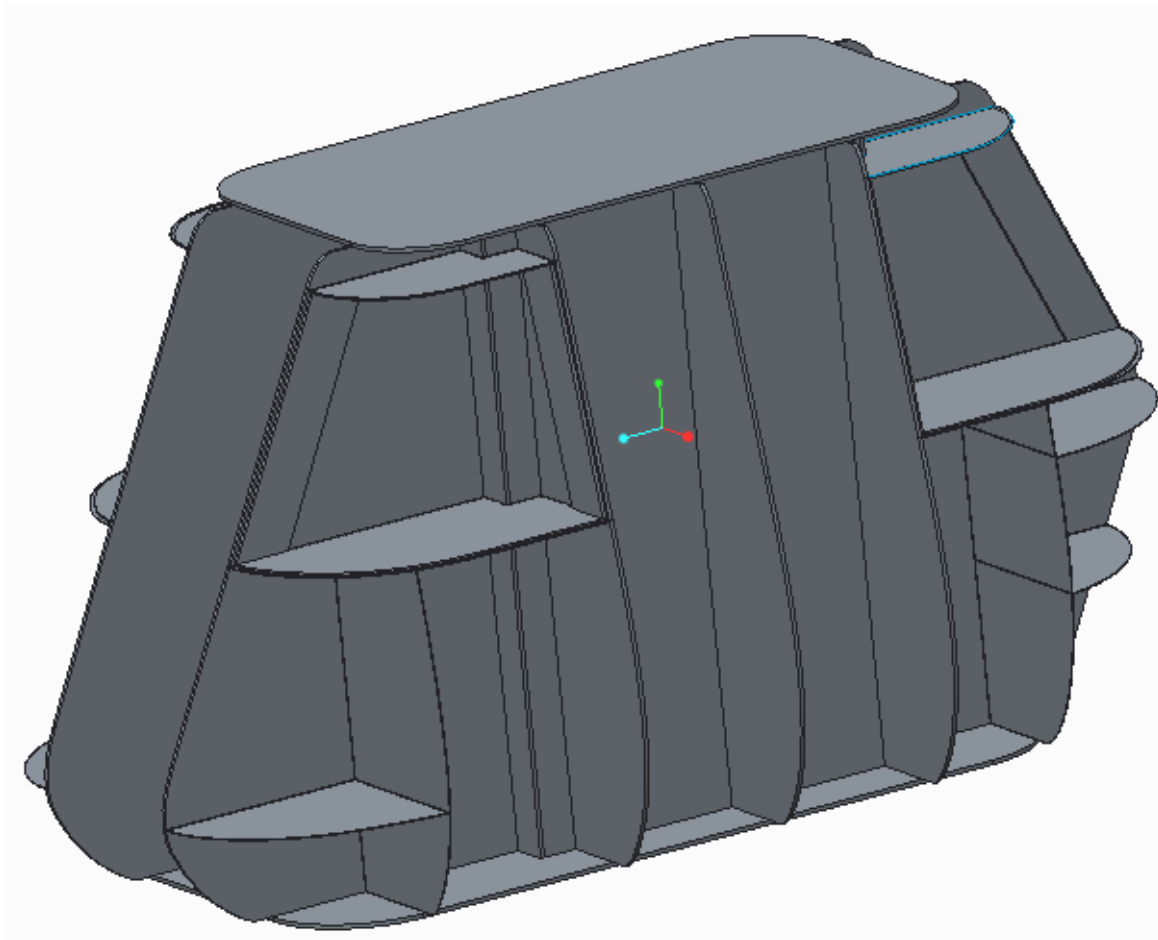

# Ritningar

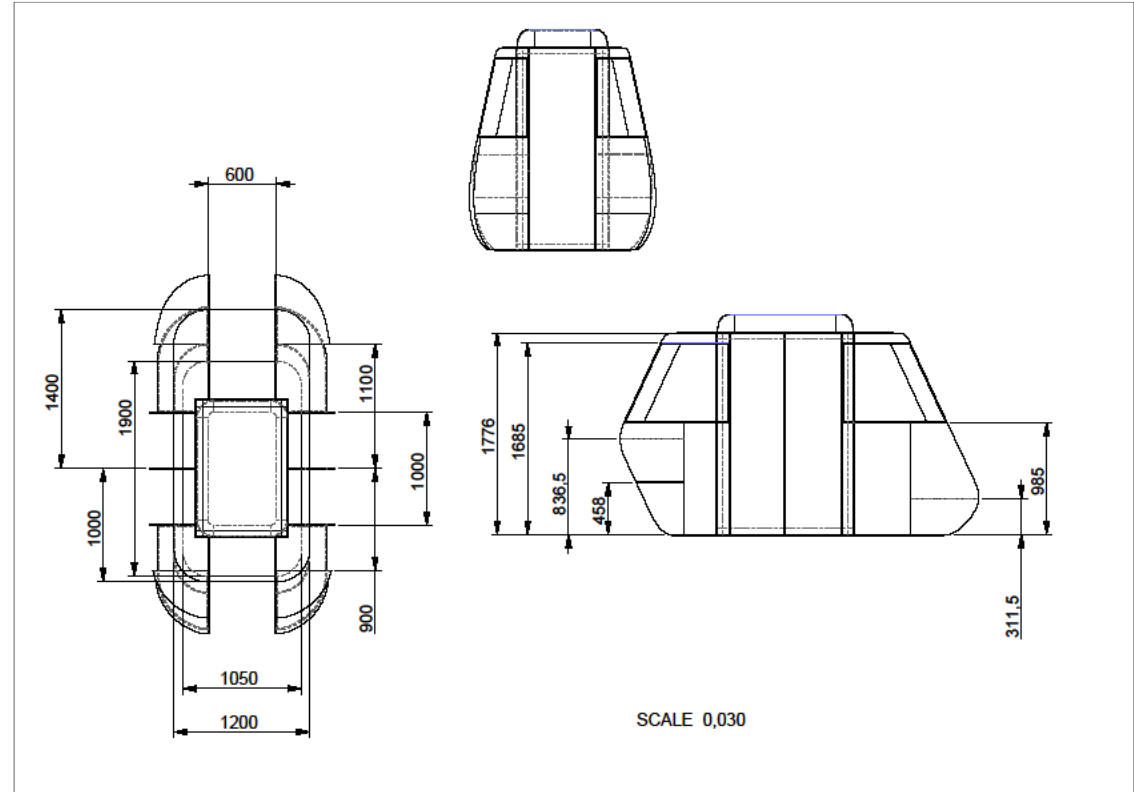
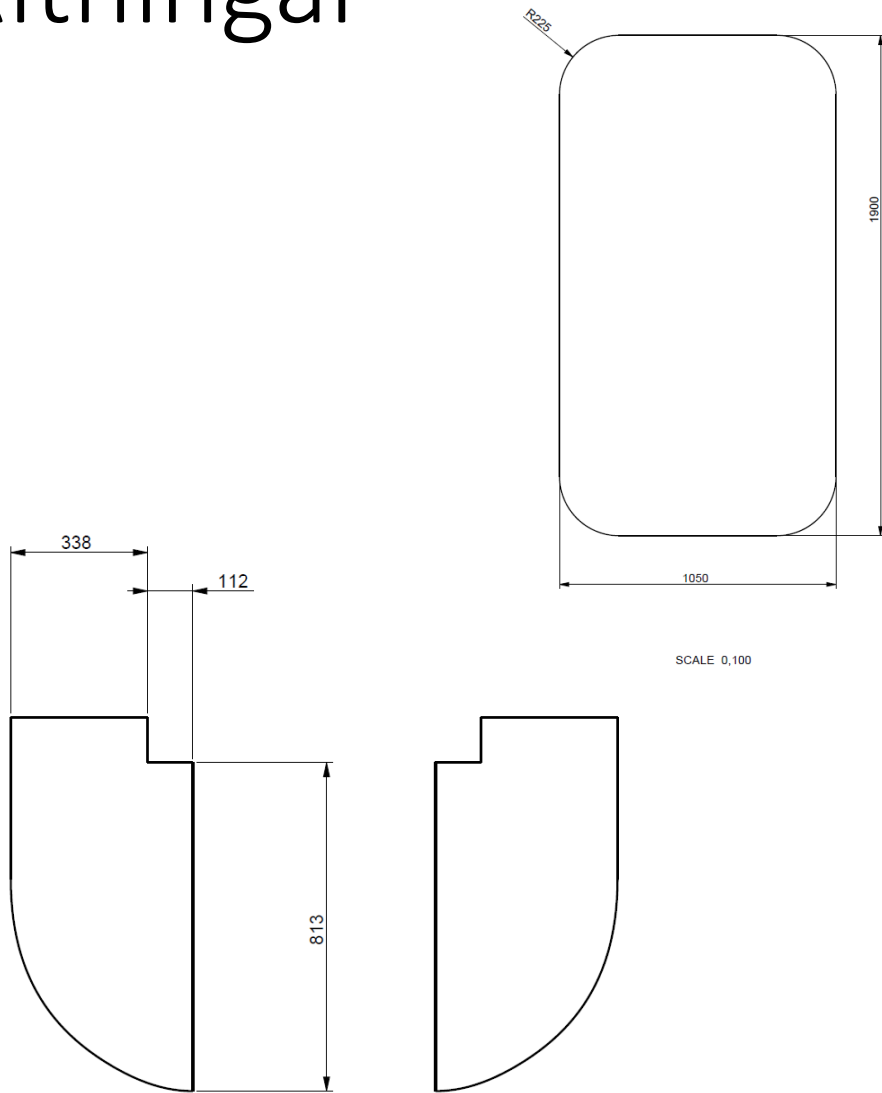

# Skalmodell

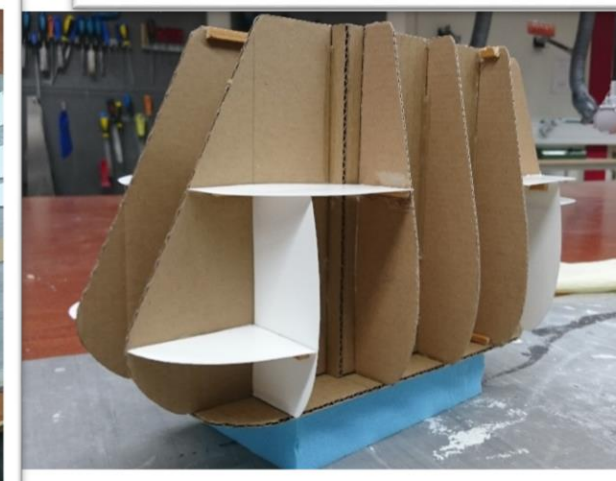
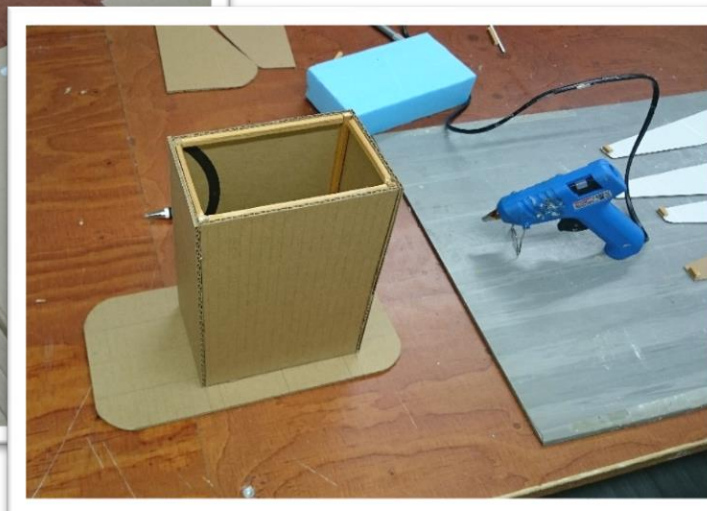
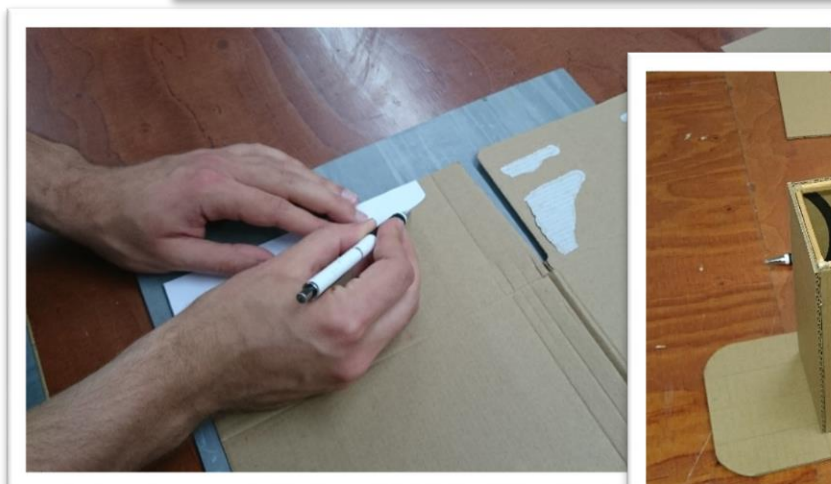
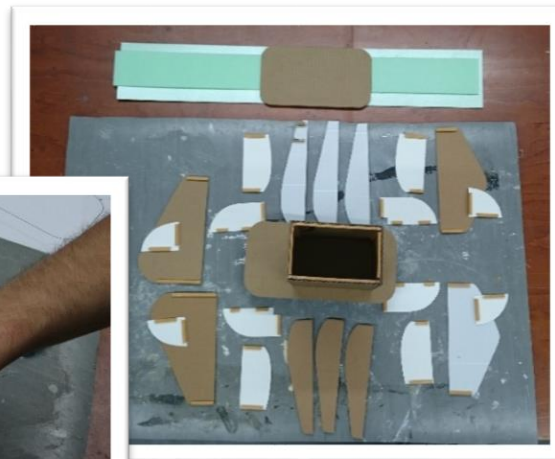
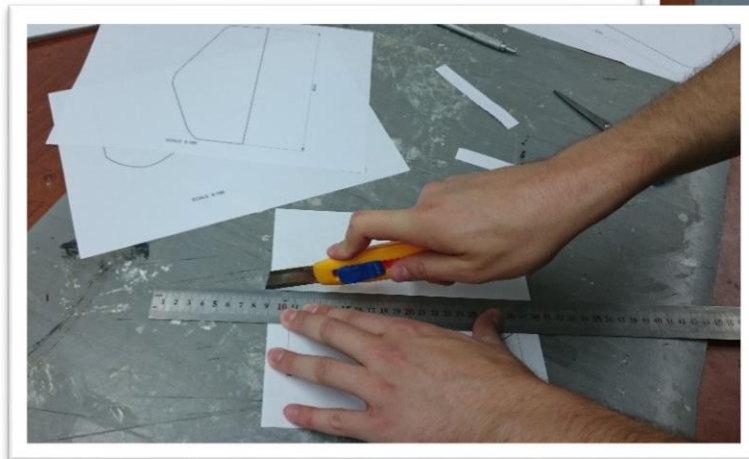

# Nestning

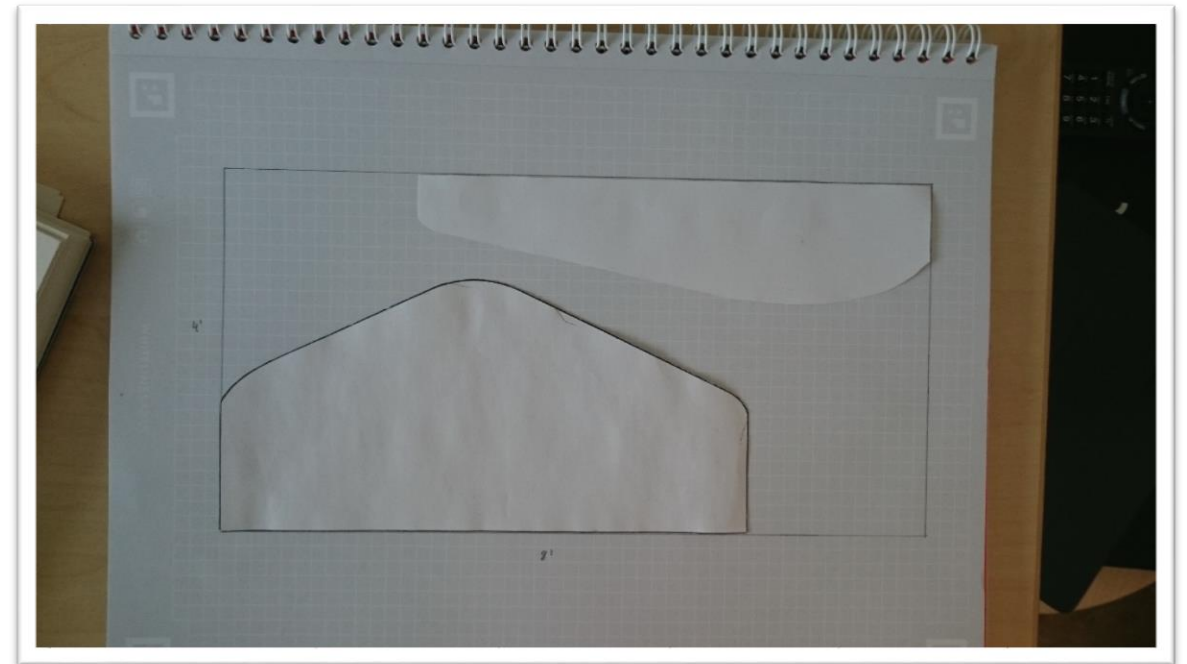
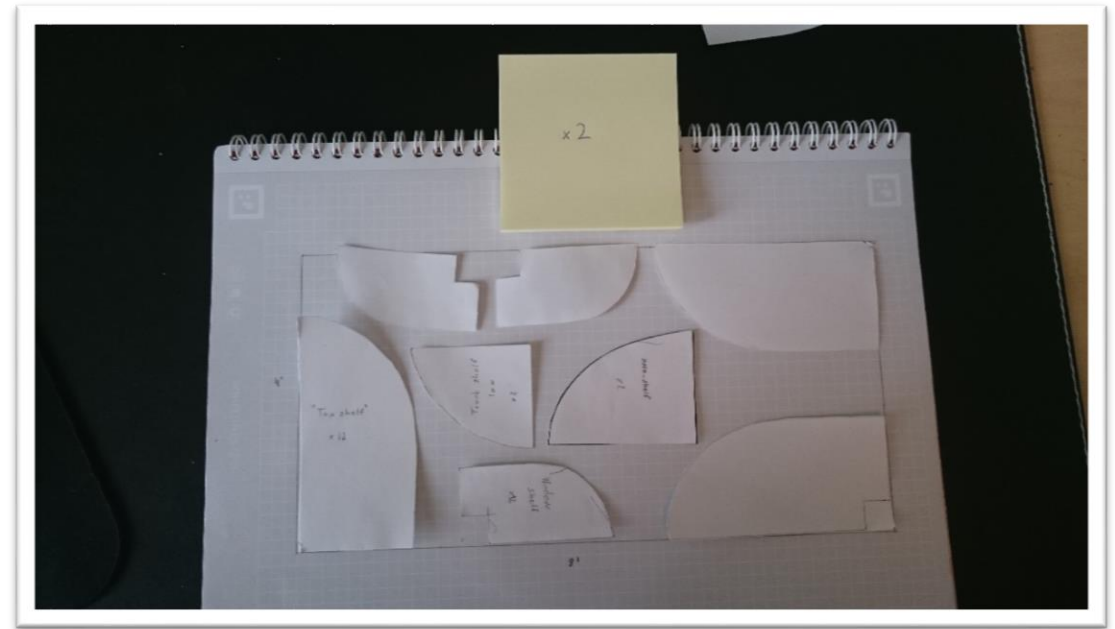
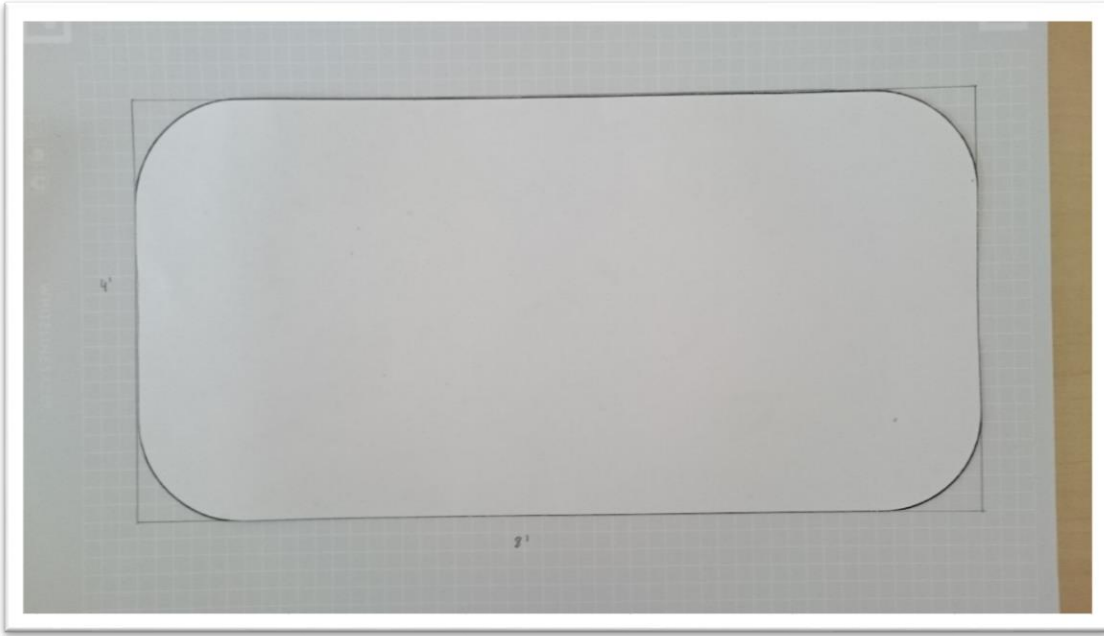

# Rendering



# Resan till San Jose, Kalifornien

- Flygresan
- 4th of July
- Boende i San Jose
- Arbetet börjar



# Trä

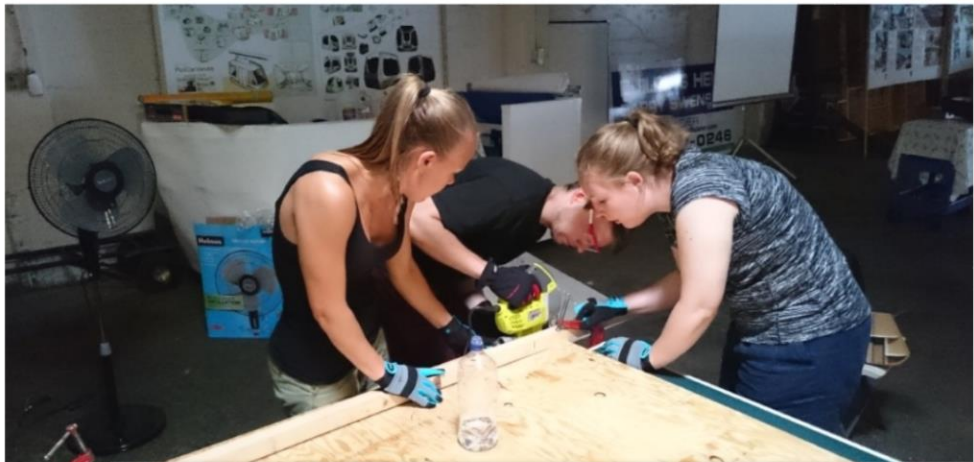



# Cellplast

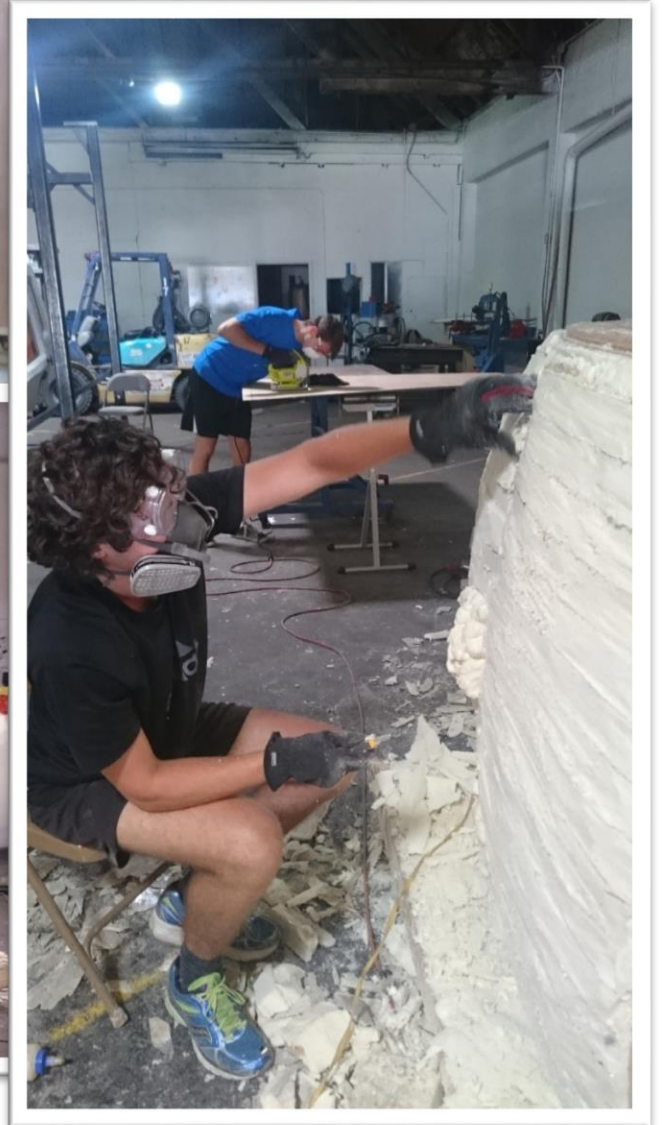

# Fönster



# Spackling och slipning



# Fortsatt arbete



# S.T.E.A.M Festival

- Amerikansk mässa på flygfält i San Jose
- Presentera Spartan Superway för allmänheten
- Skaka hand med borgmästaren
- Trafikproblem i Silicon Valley
- PRT - en verklig lösning på problemet



# Motgångar

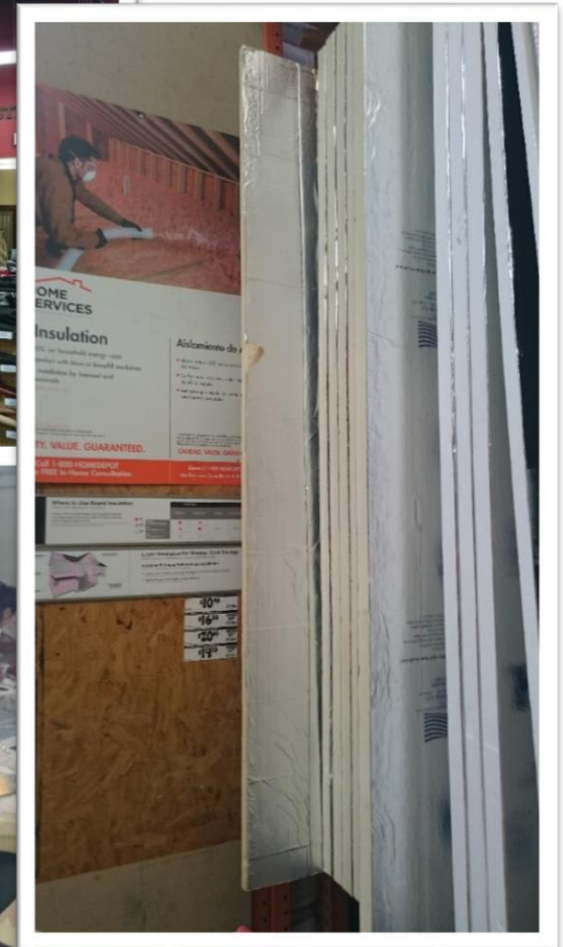

# Lärdomar

- Lägg mycket krut i projektets tidiga faser
- Svårt att förutse vad som tar tid
- Befäst förväntningar
- Fysisk skalmodell underlättar kommunikation
- Kulturskillnader



# Slutsats

- Utvecklande att driva ett projekt så långt
- Lärrikt att arbeta i internationell miljö
- Administrativt arbete tar tid





# Internship

- Administrativt
  - Eget ansvar
  - Dribblande med papper
    - Universitet
    - Visum
  - Hjälpsam och trevlig personal
  - Projektkurs
    - Stipendium
    - Försäkring
- Fortsatt samarbete?



Tack för oss!

Frågor?

